



# ACRYLIC PATIO COVERS INSTALLATION GUIDE

Complete Installation Guidelines for  
Installing a Conventional or Gable  
Style, Acrylite Acrylic Patio Covers.

Acrylic **Patio**  
**Covers**  
**DIRECT**



## CONTENTS

1	Introduction .....	3
2	System Design Manual .....	3
3	Tools & Hardware.....	4
4	Do's & Don'ts.....	5
5	The Roof Components.....	6
6	Getting Started .....	7
7	Ordering .....	8
7.1	Contact Information.....	8
7.2	Size Of Your Cover? .....	8
7.3	Which Type or Style Of Cover? .....	8
7.4	What Type Of Glazing Do You Require? .....	8
7.5	How Wide Will The Roof Panels Be? .....	8
7.6	Where Will Your Cover Attach?.....	8
7.7	What Color Of Powder Coated Framework Would You Like? .....	8
7.8	What Type Of Framework (Post & Beam) Will Support The Cover?.....	8
8	Your Roof.....	10
8.1	Gable on Roof .....	10
8.2	Gable Against Wall.....	10
8.3	Gable Free Standing .....	10
8.4	Conventional Against Fascia.....	1
8.5	Conventional Against Wall.....	1
8.6	Conventional with SkyLift Hardware.....	1
9	Fastening The Post Base Plates .....	1
10	Installing The Posts .....	1
11	Inserting The Top Shoes.....	2
12	Standard I-Beam(s) .....	2
13	Installing The Hanging Rail .....	2
13.1	Against The Wall .....	3
13.2	On The Fascia .....	3
13.3	On Roof Mounted Posts .....	3
13.4	On SkyLift Hardware .....	3
14	Gable Beams.....	4
14.1	Against The Wall .....	4
14.2	On The Roof.....	4
14.3	SkyLift Hardware .....	5
15	Connecting Two Beams With Brackets .....	5
16	The Gable Ridge Beam.....	6
17	Installing The T-Bars .....	6
17.1	Into Hanging Rail Or Ridge Beam .....	6
18	Installing The Gutter.....	8
19	Installing The Side Fascia .....	8
20	Gasketing & T-Bar End Caps .....	9





21 Installing Roof Panels..... 10

22 Flashing Your Roof ..... 10

23 Installing The T-Bar Caps ..... 11

24 Optional Components ..... 12

    24.1 Corner Gusset ..... 12

    24.2 Ridge End Scroll ..... 12

    24.3 I-Beam End Scroll ..... 12

25 Posts Against The House ..... 12

26 Splices ..... 13

    26.1 Splicing Beams..... 13

    26.2 Splicing the Hanging Rail..... 13

    26.3 Splicing the Gutter ..... 13

27 Complete ..... 14

28 Care & Maintenance ..... 14

    28.1 Acrylic Sheet ..... 14

    28.2 Gasketing and Sealants..... 14

    28.3 Aluminum Components..... 14

    28.4 The Roof System..... 14

29 Assistance..... 15



## 1 INTRODUCTION

This guide was designed to make the installation of the T-Bar Roof System as simple and straightforward as the system itself. Although individual conditions may vary and application methods are numerous, the information contained herein is based on general standards used in most applications.

It is strongly recommended that you read this guide completely before proceeding with your installation. Recommendations are made in regard to specific products and failure to follow such may void any warranty associated with these products. If you are unclear on any of the points described herein, be sure to contact your supplier for clarification before proceeding. Having a full understanding of your roof and the appropriate installation, handling and maintenance techniques will not only make the installation easier, but also reduce the possibility of frustration or problems.

Read this guide cover to cover, gather up your tools, layout your components and roll up your sleeves. Before long, with a full understanding of these guidelines, you will have installed a top quality roof that will withstand the test of time.

## 2 SYSTEM DESIGN MANUAL

Design is in accordance with the 2003 International Building Code, AA ASM 35 and Parts 1-A and 1-B of the Aluminum Design Manual AA ADM 1.

Provisions for Patio Covers as set forth in Appendix I of 2003 International Building Code apply.

Mechanical properties of aluminum alloys are provided in AA ASM 35 and Parts 1-A and 1-B of the Aluminum Design Manual AA ADM 1.

Structural design load requirements to be as specified by governing building codes and bodies, local ordinances, project specifications and/or regulatory authorities.

Follow all notes and recommendations contained within this manual.

Refer to Installation Guide for care and maintenance.

Minimum recommended pitch for roofs is 1/4" per foot or 1.19 degrees slope.

Information contained within this manual can be applied for most applications of patio covers. However where individual conditions and applications vary, separate engineering is required.

Base building structure to which canopy system is attached to provide required seismic restraint.

The procedures for determining net design wind pressures ( $p_{net}$ ) is provided in subsection 1609.6.2.2 Components and Cladding of the 2003 International Building Code, section 1609 Wind Loads.

Using the code provisions a 12.2 psf net design wind pressure is given for the following conditions:

- 85 miles per hour (37.4 m/s) nominal design 3-second gust wind speed.
- importance factor of 1.0
- exposure B — urban and suburban areas, wooded areas or other terrain with numerous closely spaced obstructions having the size of single—family dwellings or larger. Exposure B shall be assumed unless the site meets the definition of another type of exposure.
- mean roof height of 30 feet

Many patio conditions fit within these criteria. Consult the International Building Code and local building jurisdictional authorities where other conditions apply for determination of the net design wind pressure.

### 3 TOOLS & HARDWARE

- Tape Measure.
- Square.
- Level.
- Felt tip marker and/or Grease pencil.
- No.2 Robertson screwdriver (Red handle) and/or Phillips Screwdriver.
- Electric drill with 3/16" diameter drill bit.
- Rubber Mallet.
- Utility knife.
- Pliers.
- Plumb Line.
- Chalk Line.
- Step or Extension Ladders. 2 if more than one installer (Suitable to reach beyond your highest intended height)
- Soft, non-abrasive cleaning rags.

The following items may be required; depending on the amount of altering you will be doing to the supplied products.

- Circular saw with blades suitable for cutting aluminum and plastics.
- Hacksaw and/or Miter saw.
- Tin snips
- Silicone sealant (Recommend -Tremco Spectrum II, G.E. Silpruf or Dow 795).
- Metal roof flashing (no less than 0.029 gauge).
- Safety Goggles.

NOTE: Various types of fasteners may be provided for varying circumstances or be substituted depending on engineering or design requirements. In such cases, alternative types of screwdriver(s) or fastening devices may be required.

## 4 Do's & DON'TS

DO'S	DON'TS
DO, whenever possible, follow the instructions in this guide.	DON'T proceed without reading this guide.
DO check local building regulations before you begin.	DON'T assume that any structure will withstand the loads exerted without checking.
DO make sure your superstructure is square and true.	DON'T leave even the slightest errors uncorrected.
DO use only full lengths of aluminum bars, caps and gasketing unless where possible.	DON'T join two or more lengths together unless specifically indicated with the use of a splice.
DO use only fasteners described in this guide and/or provided with your roof.	DON'T use fasteners of a quality, length or type contrary to those described herein and/or provided with your roof.
DO fasten all components as described herein, paying particular attention to the spacing and frequency.	DON'T apply fasteners in areas not specifically outlined herein or spaced other than described herein.
DO remove any burrs from aluminum sections after doing any cutting.	DON'T install gasketing to aluminum sections without first removing burrs or metal shavings.
DO cut all gaskets square.	DON'T cut any gaskets on an angle.
DO keep gaskets free of aluminum filings, sawdust and any other such dirt and debris.	DON'T install dirty gasketing or a positive seal may be compromised.
DO store all materials indoors, under cover or keep them cool and protected from the sun and elements until installation.	DON'T store materials in direct sunlight. Expansion prior to installation can cause installation difficulties and the protective masking can stick to acrylic panels.
DO use only recommended silicone sealants.	DON'T use non-recommended silicone sealants. Some sealants can cause material deterioration.
DO avoid using sealants unless specifically outlined in this guide and in all cases do so sparingly.	DON'T use sealants unless specifically outlined herein.
DO make sure that wood stain or finish is thoroughly dry before attaching any roof component to it.	DON'T start before the stain is dry or use wood stains that contain petroleum distillates. DON'T bring stain or finish in contact with any roof component.

## 5 THE ROOF COMPONENTS

The following list will illustrate the individual components and should assist in their identification. The type and size of roof that you have ordered will determine which specific roof components are provided and the quantity of such. Some of the hardware is common to all roofs regardless of type and size, however not all components are applicable to all roofs and therefore not be provided in your roof. Some of the components are optional in all cases and only be supplied when specifically requested. By fully reading through this guide and acquiring an understanding of how to assemble the roof, you should be able to make a determination of which components are appropriate to your specific application.



Acrylic Sheet

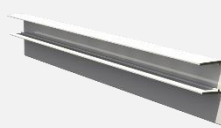

F-Section

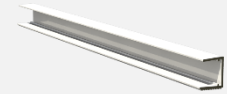

Terminal Section



T-Bar



T-Bar Cap



T-Bar End Cap



Hanging Rail

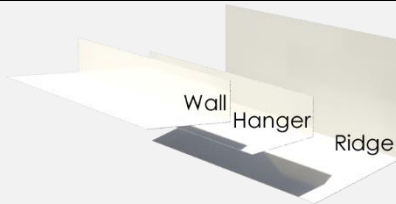

Flashing

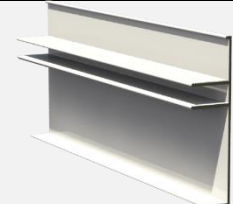

Side Fascia



Low Profile Gutter



Colonial Gutter



Gutter Plug



4 1/2' I-Beam



6' I-Beam



Heavy I-Beam





Post

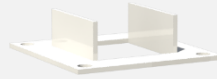

Post Base

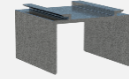

Post Top Shoe



Post Bottom Shoe



I-Beam Scroll

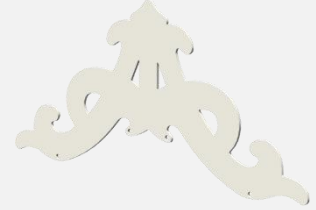

Ridge Scroll



Corner Gusset



Wall Mount Brackets

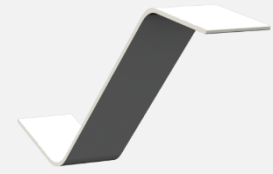

Roof Rail Bracket

## 6 GETTING STARTED

You will need to know your roof pitch or slope as a before you can begin to install your components. In most cases. The single most important determining factor is the highest point at which you can fasten to against your house. The difference between this height and what represents a suitable roof height at the low side or front of your roof will determine your pitch.

NOTE: The minimum recommended pitch is  $\frac{1}{4}$ " per foot or your roof should rise  $\frac{1}{4}$ " for every 12" on projection. i.e.: 8 ft projection will require a minimum of  $(8 \times \frac{1}{4}) = 2$ " rise.

In cases where there is no restrictions on your back height (two story blank walls, etc.) you may choose to determine a suitable front height and then work back towards the building to determine where to position the Hanging Rail or high point of your roof. In all cases more pitch is better. Cleaning, maintenance and load requirements are all factors here and the greater the pitch, the less the concern.

1. Determine where and how high you can fasten to your wall or fascia taking notice of second story windows, etc. When fastening to the fascia it should be noted that the fascia or faceboard should be no less than 5 inches.
2. Determine a suitable front height. In most cases you will desire a height that an individual can stand under. A reasonable height would be approximately 80 inches. This will be measured from the floor, deck or pad to the underside of the I-Beam.
3. Once both back and front heights are determined, you should now be able to proceed with preparing and installing your roof system.



## 7 ORDERING

### To Prepare Your Cover We Need To Know The Following

Fill In The Blanks Or Circle The Appropriate Selection. Fax or Email this page and the following to start your order. *Unanswered Questions May Lead To Delays.*

#### 7.1 CONTACT INFORMATION

Your Name: \_\_\_\_\_ Email: \_\_\_\_\_  
 Address: \_\_\_\_\_ Phone: \_\_\_\_\_

#### 7.2 SIZE OF YOUR COVER?

Width: \_\_\_\_\_ x Projection: \_\_\_\_\_  
*Not Just Your Deck Or Patio - Be Sure To Include Any Overhangs If Required*

- Check If Stock Size Is OK (Gable Width: + 8"-9" Projection: + 3"-4"  
 Conventional Width & Projection: +3"-5")

#### 7.3 WHICH TYPE OR STYLE OF COVER?

Conventional (*Single Slope*) Style    Gable (*Double Slope*) Style

#### 7.4 WHAT TYPE OF GLAZING DO YOU REQUIRE?

Cool Blue HeatStop    Solar Cool White    Bronze    Clear

#### 7.5 HOW WIDE WILL THE ROOF PANELS BE?

*Applies To Acrylic Panels Only - Refer To Engineering For Suitability*

Four Foot (47 1/4" Panels / 48" Centers)    Two Foot (23 1/2" Panels / 24 1/4" Centers)

#### 7.6 WHERE WILL YOUR COVER ATTACH?

- 1 Above The Roof / Elevated Hanger
  - SkyLift Roof Riser Hardware
  - Conventional Post with Shoes & Bracket
- 2 Beam Brackets Directly On The Roof (Gable Roofs ONLY)
- 3 Fascia (Overhang) - May Require Removal of Existing Gutter
- 4 Against The House Wall - Siding, Stucco, Brick, Etc.
- 5 Free-Standing – Additional Posts And Beams Will Be Required

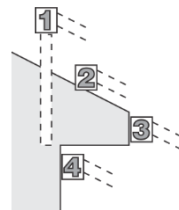

#### 7.7 WHAT COLOR OF POWDER COATED FRAMEWORK WOULD YOU LIKE?

White (Standard)    Brown    Black    Beige    Custom Color (Add \$1000): \_\_\_\_\_

#### 7.8 WHAT TYPE OF FRAMEWORK (POST & BEAM) WILL SUPPORT THE COVER?

Aluminum (Supplied Standard)    Wood Glulam    Existing Post & Beam

Note: For Supplied Aluminum I-Beams Maximum Distance Between Posts Is 20 Feet.  
 All Gable Roofs Require Center Post or Cross Beam with Short Ridge Support Post.

### Illustrate Your Details On The Drawings On The Following Page

Include As Much Information As Necessary

List Further Details and/or Additional Requirements You May Have?

*Do You Require Additional Posts, Beams, Gutter Supplies, Etc.*



## 8 YOUR ROOF

The steps in completing your roof can vary depending on the style of roof and the style of installation. You should determine which of the following scenarios describes your roof and follow the steps outlined therein. Of course there may be necessity to wander outside the prescribed steps for your roof, so it always a good idea to read this entire guide to get a broader view of the system and various application techniques.

### 8.1 GABLE ON ROOF

- INSTALL POST BASE PLATES  
*9 Fastening The Post Base Plates*
- INSTALL POSTS  
*10 Installing The Posts*
- INSTALL ROOF MOUNT BRACKETS FOR LOWER I-BEAMS  
*14.2 On The Roof*
- INSERT TOP SHOES INTO LOWER I-BEAMS AND INSTALL ON POSTS  
*11 Inserting The Top Shoes*  
*12 Standard I-Beam(s)*
- INSTALL HORIZONTAL CROSS BEAM  
*15 Connecting Two Beams With Brackets*
  - a. Beam Only from left to right
  - b. For added strength Post from ridge to ground
- INSTALL RIDGE BEAM  
*16 The Gable Ridge Beam*
- INSTALL T-BARS FROM RIDGE BEAM TO RIGHT AND LEFT I-BEAMS  
*17 Installing The T-Bars*
- INSTALL GUTTERS AND DRILL HOLE FOR DOWNPIPE  
*18 Installing The Gutter*
- INSTALL SIDE FASCIA AND 1x1 CORNERS  
*19 Installing The Side Fascia*
- INSERT ACRYLIC PANELS, FLASHING AND T-BAR CAPS  
*21 Installing Roof Panels*  
*22 Flashing Your Roof*  
*23 Installing The T-Bar Caps*
- INSTALL SCROLLS AND/OR CORNER GUSSETS (OPTIONAL)  
*24 Optional Components*
- INSTALL DOWNPIPE OR RAIN CHAIN WHERE NEEDED

### 8.2 GABLE AGAINST WALL

- INSTALL POST BASE PLATES  
*9 Fastening The Post Base Plates*
- INSTALL WALL MOUNT BRACKETS ONTO I-BEAM AND RIDGE BEAM
- INSTALL POSTS  
*10 Installing The Posts*

- INSERT TOP SHOES INTO LOWER I-BEAMS AND INSTALL ON POSTS  
*11 Inserting The Top Shoes*  
*12 Standard I-Beam(s)*
- AND ON WALL  
*14.1 Against The Wall*
- (OPTIONAL POST UNDER WALL MOUNT BRACKET)  
*25 Posts Against The House*
- INSTALL HORIZONTAL CROSS BEAM  
*15 Connecting Two Beams With Brackets*
  - a. Beam Only from left to right
  - b. For added strength Post from ridge to ground
- INSTALL RIDGE BEAM  
*16 The Gable Ridge Beam*
- INSTALL T-BARS FROM RIDGE BEAM TO RIGHT AND LEFT I-BEAMS  
*17 Installing The T-Bars*
- INSTALL GUTTERS AND DRILL HOLE FOR DOWNPIPE  
*18 Installing The Gutter*
- INSTALL SIDE FASCIA AND 1x1 CORNERS  
*19 Installing The Side Fascia*
- INSTALL AND SEAL WALL FLASHING INTO T-BAR
- INSERT ACRYLIC PANELS, FLASHING AND T-BAR CAPS  
*21 Installing Roof Panels*  
*22 Flashing Your Roof*  
*23 Installing The T-Bar Caps*
- INSTALL SCROLLS AND/OR CORNER GUSSETS (OPTIONAL)  
*24 Optional Components*
- INSTALL DOWNPIPE OR RAIN CHAIN WHERE NEEDED

### 8.3 GABLE FREE STANDING

- INSTALL FREE STANDING POST BASE  
*9 Fastening The Post Base Plates*
- INSTALL POSTS  
*10 Installing The Posts*
- INSERT TOP SHOES INTO I-BEAMS AND INSTALL ON POSTS  
*11 Inserting The Top Shoes*  
*12 Standard I-Beam(s)*
- INSTALL CROSS BEAM  
*15 Connecting Two Beams With Brackets*

- a. Beam Only from left to right
- b. For added strength Post from ridge to ground

- INSTALL RIDGE BEAM  
*16 The Gable Ridge Beam*
- INSTALL T-BARS FROM RIDGE BEAM TO RIGHT AND LEFT I-BEAMS  
*17 Installing The T-Bars*
- INSTALL GUTTERS AND DRILL HOLE FOR DOWNPIPE  
*18 Installing The Gutter*
- INSTALL SIDE FASCIA AND 1x1 CORNERS (FRONT AND BACK)  
*19 Installing The Side Fascia*
- INSERT ACRYLIC PANELS, FLASHING AND T-BAR CAPS  
*21 Installing Roof Panels*  
*22 Flashing Your Roof*  
*23 Installing The T-Bar Caps*
- INSTALL SCROLLS AND/OR CORNER GUSSETS FOR ADDED SUPPORT  
*24 Optional Components*
- INSTALL DOWNPIPE OR RAIN CHAIN WHERE NEEDED

#### **8.4 CONVENTIONAL AGAINST FASCIA**

- INSTALL HANGING RAIL ONTO FASCIA  
*13.2 On The Fascia*
- INSTALL POST BASE  
*9 Fastening The Post Base Plates*
- INSTALL POSTS  
*10 Installing The Posts*
- INSERT TOP SHOES INTO I-BEAM AND INSTALL ON POSTS  
*11 Inserting The Top Shoes*  
*12 Standard I-Beam(s)*
- INSTALL T-BARS FROM HANGING RAIL TO I-BEAM  
*17 Installing The T-Bars*
- INSTALL GUTTERS AND DRILL HOLE FOR DOWNPIPE  
*18 Installing The Gutter*
- INSTALL SIDE FASCIA AND 1x1 CORNERS (LEFT AND RIGHT)  
*19 Installing The Side Fascia*
- INSERT ACRYLIC PANELS, FLASHING AND T-BAR CAPS  
*21 Installing Roof Panels*  
*22 Flashing Your Roof*  
*23 Installing The T-Bar Caps*
- INSTALL SCROLLS AND/OR CORNER GUSSETS FOR ADDED SUPPORT  
*24 Optional Components*
- INSTALL DOWNPIPE OR RAIN CHAIN WHERE NEEDED

#### **8.5 CONVENTIONAL AGAINST WALL**

- INSTALL HANGING RAIL ONTO WALL  
*13.1 Against The Wall*
- INSTALL POST BASE  
*9 Fastening The Post Base Plates*
- INSTALL POSTS  
*10 Installing The Posts*
- INSERT TOP SHOES INTO I-BEAM AND INSTALL ON POSTS  
*11 Inserting The Top Shoes*  
*12 Standard I-Beam(s)*
- INSTALL T-BARS FROM HANGING RAIL TO I-BEAM  
*17 Installing The T-Bars*
- INSTALL GUTTERS AND DRILL HOLE FOR DOWNPIPE  
*18 Installing The Gutter*
- INSTALL SIDE FASCIA AND 1x1 CORNERS (LEFT AND RIGHT)  
*19 Installing The Side Fascia*
- INSERT ACRYLIC PANELS, FLASHING AND T-BAR CAPS  
*21 Installing Roof Panels*  
*22 Flashing Your Roof*  
*23 Installing The T-Bar Caps*
- INSTALL DOWNPIPE OR RAIN CHAIN WHERE NEEDED

#### **8.6 CONVENTIONAL WITH SKYLIFT HARDWARE**

- INSTALL POST BASE  
*9 Fastening The Post Base Plates*
- INSTALL POSTS  
*10 Installing The Posts*
- INSTALL SKYLIFT HARDWARE
- INSTALL HANGING RAIL INTO SKYLIFT HARDWARE
- INSERT TOP SHOES INTO I-BEAM AND INSTALL ON POSTS  
*11 Inserting The Top Shoes*  
*12 Standard I-Beam(s)*
- INSTALL T-BARS FROM HANGING RAIL TO I-BEAM  
*17 Installing The T-Bars*
- INSTALL GUTTERS  
*18 Installing The Gutter*
- INSTALL SIDE FASCIA AND 1x1 CORNERS (LEFT AND RIGHT)  
*19 Installing The Side Fascia*
- INSERT ACRYLIC PANELS, FLASHING AND T-BAR CAPS  
*21 Installing Roof Panels*  
*22 Flashing Your Roof*  
*23 Installing The T-Bar Caps*
- INSTALL SCROLLS AND/OR CORNER GUSSETS FOR ADDED SUPPORT  
*24 Optional Components*
- INSTALL DOWNPIPE OR RAIN CHAIN WHERE NEEDED



## 9 FASTENING THE POST BASE PLATES

Primary support of any Patio Cover will of course be the posts. If you are using your posts of your own design or the posts already exist you may disregard this section. In all cases where the standard aluminum posts are being used the base is fastened down in one of the following methods depending on where they are being attached and what type of surface they are being attached to.

The Post Base Plate has four pre-punched holes for the fasteners which will vary according to the surface being fastened to.

As every Patio Cover installation is unique there are numerous types of locations and therefore various surfaces and materials being attached to. These can include concrete patios or concrete footings, wood decks, rooftop decks or even the roof itself. In all cases you should use fasteners that are strong enough and penetrated deep enough to withstand the conditions being placed on them. Be aware that although not always obvious, wind uplift should play a strong role in the determination of the type of fastener used. You may wish to consult your local building regulations for assistance in making this decision.

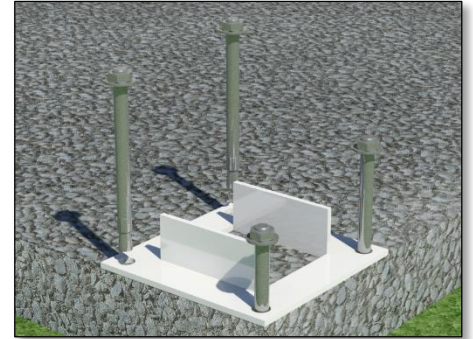

## 10 INSTALLING THE POSTS

The posts will now need to be cut to length before installation. As with most of the roof system's aluminum components, they can be easily cut with a circular saw, miter saw or hacksaw.

The position of the post will ultimately determine its length. Posts supporting the common beam for a conventional roof will be typically the approximate

height that an individual can walk under. This can be the same for the posts supporting the left and right beams in a gable roof while the post supporting the ridge beam can be significantly longer. Be certain of the posts position and purpose before you begin cutting.

**NOTE:** Of particular note here is that the length of the posts will dictate the slope of your roof's gutter. Therefore the posts supporting any beam will progressively shorter to allow the beam to slope along its length which will allow for a slope in the gutter when it is installed later. This is where you should determine where your roof will drain and plan for the shortest post to be at or near this point.

The standard square posts simply slide over the two upward legs on either of the Base Plates or Post Shoes. You will then fasten with two self-tapping screws through each side of the post about  $\frac{3}{4}$ " up from the bottom.

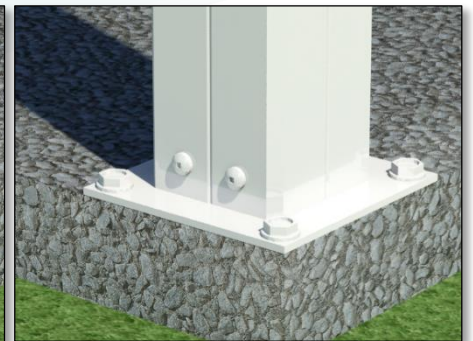

## 11 INSERTING THE TOP SHOES

You should now insert the Post Top Shoes into the I-Beam(s) by sliding them in from either end of the Beam. There should be one Shoe for every post.

When these Top Shoes are positioned along the length of the Beam at roughly where the Post will be positioned, you can then slide each post over the Shoe and fasten through each side of the beam as with the Base Shoes.

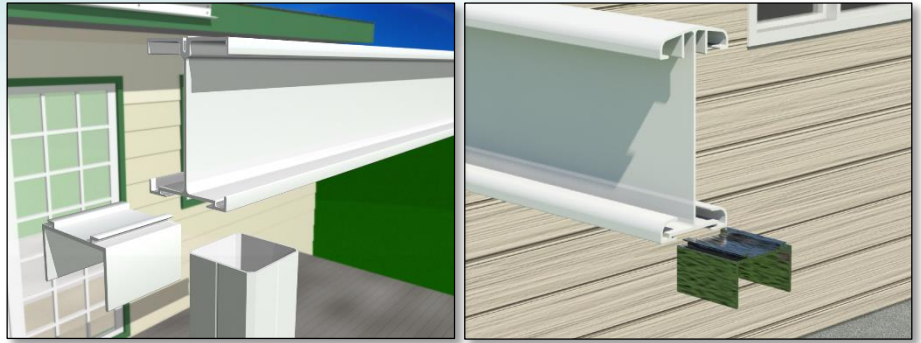

## 12 STANDARD I-BEAM(S)

When the Top Shoes (inserted earlier) are positioned along the length of the Beam at roughly where the Post will be positioned, you can then slide each post over the Shoe and fasten through each side of the beam as with the Post Bases. Once your Post is aligned level vertically in the final desired position a screw should be fastened inside the Beam down through the Post Top Shoe to prevent any further movement of the Shoe inside the Beam.



This is a good time check the pitch of your roof to be certain that your beam has a slight slope in the direction that you would like to have your gutter drain. It is important to ensure this pitch at this point as it will become extremely difficult to correct later.

## 13 INSTALLING THE HANGING RAIL

For conventional roofs the Hanging Rail is installed as the starting point. This is attached to the side of the existing building or the existing fascia at the high point of the roof.

**NOTE:** This hanging rail will be carrying much of the weight of the roof and therefore great care should be taken in ensuring that it is adequately fastened.

### 13.1 AGAINST THE WALL

When fastening to a wall the key point here is to ensure that your Hanging Rail is fastened into the structure beyond the surface, siding or similar. In standard wall surfaces it is important that the fasteners penetrate into the studs, headers, top wall plates, joists or similar. For brick, concrete or the like the Hanging rail should be fastened with anchors or similar fasteners to adequately support your roof. You may wish to check your local building requirements for suggestions on acceptable fasteners.

The fasteners should be spaced within the Hanging Rail to coincide with the Stud spacing or centers and/or similar for continuous fastening surfaces.

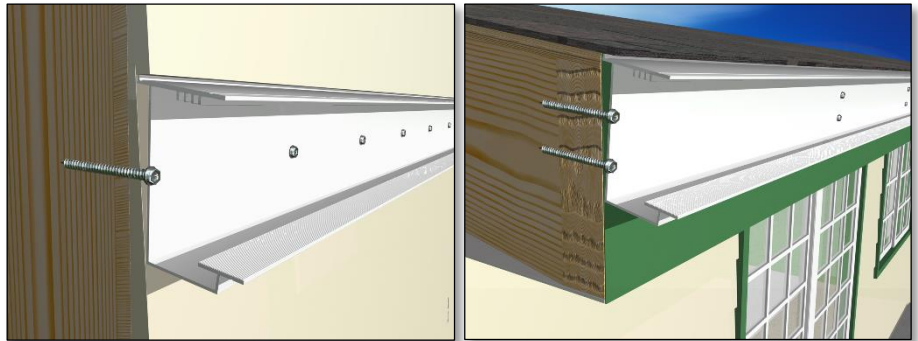

### 13.2 ON THE FASCIA

When fastening to the existing fascia of the house you should fasten through it and into each and every rafter end. Here again fastening should be done with a pair of #12 x 3½" screws spaced no more than 24" apart as the rafter ends are encountered.

### 13.3 ON ROOF MOUNTED POSTS

Posts being attached to the roof will utilize fasteners similar to that of a wood deck. Special care should be taken to rest the shoe over a roof truss, rafter or similar substructure. If access can be gained to the underside of the surface you may be able to install blocking to carry the load being added by the proposed Patio Cover post. In no case should the post base and subsequently the post be installed over unsupported roof sheathing as this will not be strong enough to support the additional load of the Patio Cover, etc. The upward flanges of the Post Base should run across the slope of the roof and not down the slope. The lower of these flanges will have to be bent slightly to stand upright (vertical) to allow the post to slide over the base.

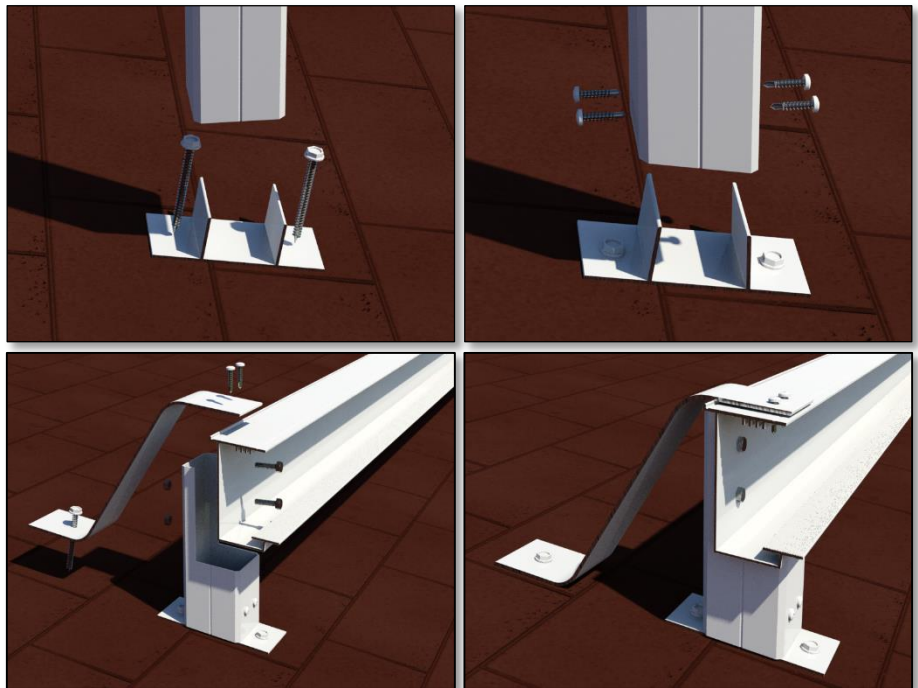

The Posts here will have to be miter cut at an angle to match the slope of the roof. If not already done the top of the post will then have to be notched to accommodate the hanging rail. The Hanging Rail is then bolted through the back and completely through the balance of the post. A Roof Rail Bracket is then screwed down through the top of the Hanging Rail with the opposing end being screwed down to the roof into the roof truss.

### 13.4 ON SKYLIFT HARDWARE

Please refer to SkyLift Hardware documentation for appropriate use of such.



## 14 GABLE BEAMS

### 14.1 AGAINST THE WALL

When an I-Beam meets with the wall of the house a Mounting Bracket can be used to secure the I-Beam to the wall. This eliminates the need for a post to support the beam here. The size of these Brackets will vary with the size of the I-Beam being used. The correct Bracket should fully insert into the I-Beam tightly with little to no room for sliding up or down. Before installing you should slide the Bracket onto the end of your beam and drill the holes through the I-Beam according to the existing holes on the flanges of the Mounting Bracket.

The next step is to fasten the Mounting Bracket to the wall of the house. Holes have been predrilled on the left and right flanges of the Brackets where the fasteners are to go. The actual position of the Bracket should be aligned with a header, rim joist or wall stud to ensure that you are fastening into more than just the sheeting and/or siding of the wall. This is critical as insufficient structure here may cause the bracket to pull free from the wall and could lead to partial or full collapse. A #12 x 3½" fastener should be used in each of the predrilled holes and all should fully engage the structure beneath the wall surface. If it is uncertain as to the structure you are fastening into it may be necessary to place a post beneath the Beam/Bracket at this point to ensure that the beam is supported sufficiently.

Once the Wall Mount Bracket is secure the I-Beam can now be inserted into the two outward flanges of the Bracket and 1/4" – 3/8" diameter thru bolts inserted into the holes drilled earlier. Affix an appropriate nut to the other side of the bolt and your beam should be secure. You can now proceed to working above this beam.

Be certain to use a fastener in every hole leaving no vacancies. You will likely require the assistance of another individual or a post or step ladder to hold the other end of the beam so that it securely rests in a horizontal position as you fasten these bolts.

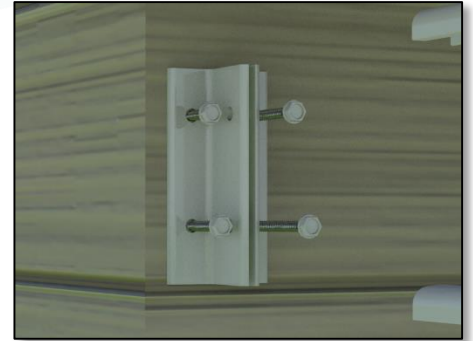

### 14.2 ON THE ROOF

As with using these Mounting Brackets against the wall #12 x 3½" fasteners are used in all of the predrilled holes. The Bracket should be positioned over a roof truss or similar substructure and care should be taken that this is never positioned over roof sheeting alone as this sheeting is likely insufficient to carry the load at this point. The top of this Bracket will need to be mitered to allow the I-beam to insert into the bracket. To determine this miter, rest the Bracket on the roof at the intended position and with a level as a guide, mark a horizontal line from the roof across the two outward flanges on the Bracket. This section can now be removed with a miter saw or hacksaw.

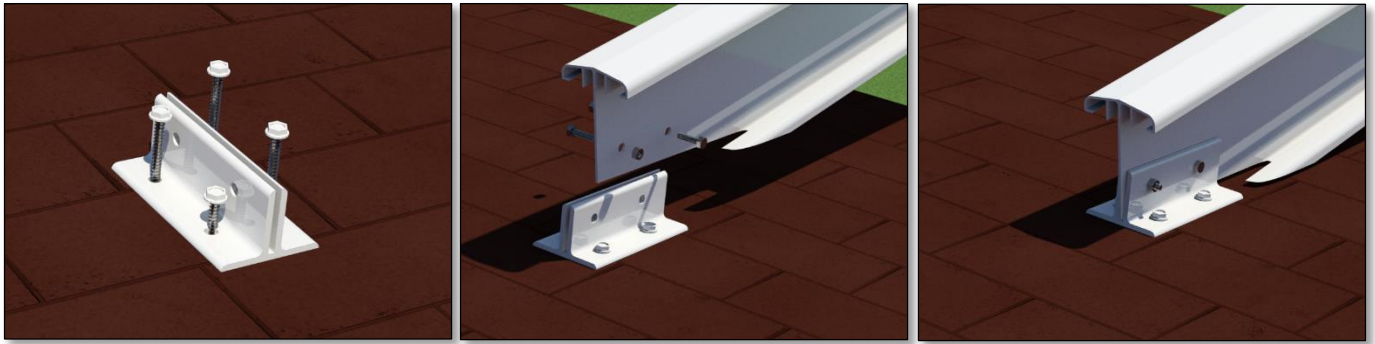

### 14.3 SKYLIFT HARDWARE

Please refer to SkyLift Hardware documentation for appropriate use of such.

## 15 CONNECTING TWO BEAMS WITH BRACKETS

Where two beams connect at right angles as in a forward cross beam in a Gable Roof it will be necessary to connect the two using Mounting Brackets. These are the same brackets as used to mount the beam to the wall. The bracket should be slid over the end of the Beam in order that the appropriate holes can be predrilled using the existing bracket as a guide. The bracket should then be inserted into the supporting beam in order that the four holes be predrilled here again using the existing bracket as a guide. At this point it should be self-explanatory as to the placement of the six 1/4" thru bolts. Be certain to install and tighten ALL bolts leaving no hole vacant.

The smaller 4½" I-Beam will insert fully into the larger 6" I-Beam, however when connecting two beams of the same size, as inserting a 6" Beam into a 6" Beam, the inserted Beam will have to be notched in order to fit. The horizontal top and bottom of the beam will have to be completely removed leaving only the center upright portion of the beam. This "notched" portion of the beam will then insert into the other same sized beam.

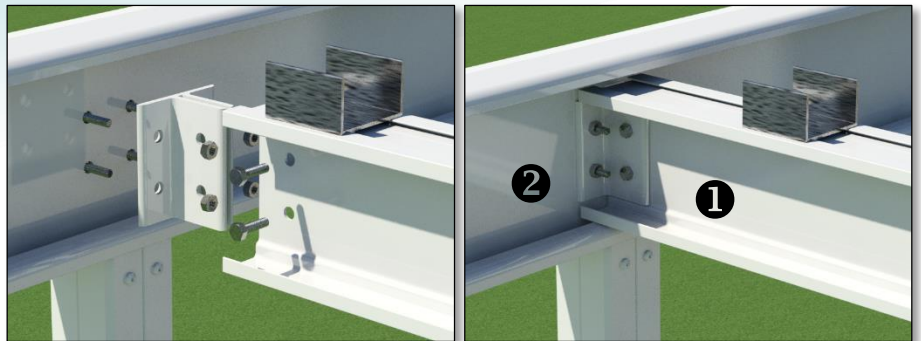

NOTE: The smaller 4½" I-Beam **1** will insert fully into the larger 6" I-Beam **2**

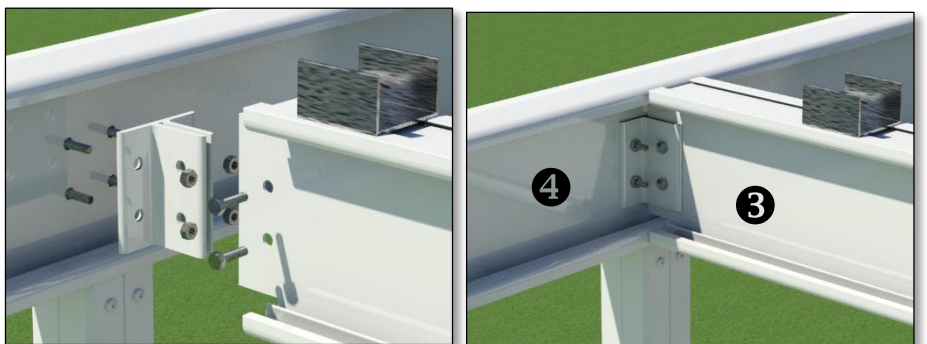

Same sized Beams **3** & **4** will require that one **3** be "notched" prior to being inserted into the other **4** beam.

## 16 THE GABLE RIDGE BEAM

The support of the Gable Ridge Beam can be done in a number of ways depending on your application. At the house or attachment end the Beam can rest on Posts as detailed in Section 11 and 12 which can rest on the roof of the house as in Section 13.3 On Roof Mounted Posts. Alternatively the Gable Beam can be attached to the wall of a high or two storey structure with Wall Mount Brackets as illustrated in 14.1 Against The Wall.

At the front end of the Beam support will be on a Post, but this post may either be supported by a horizontal cross beam or by a post that continues to the deck or patio, etc. In the case of a free-standing roof, both end of the Ridge Beam will be supported in this fashion.

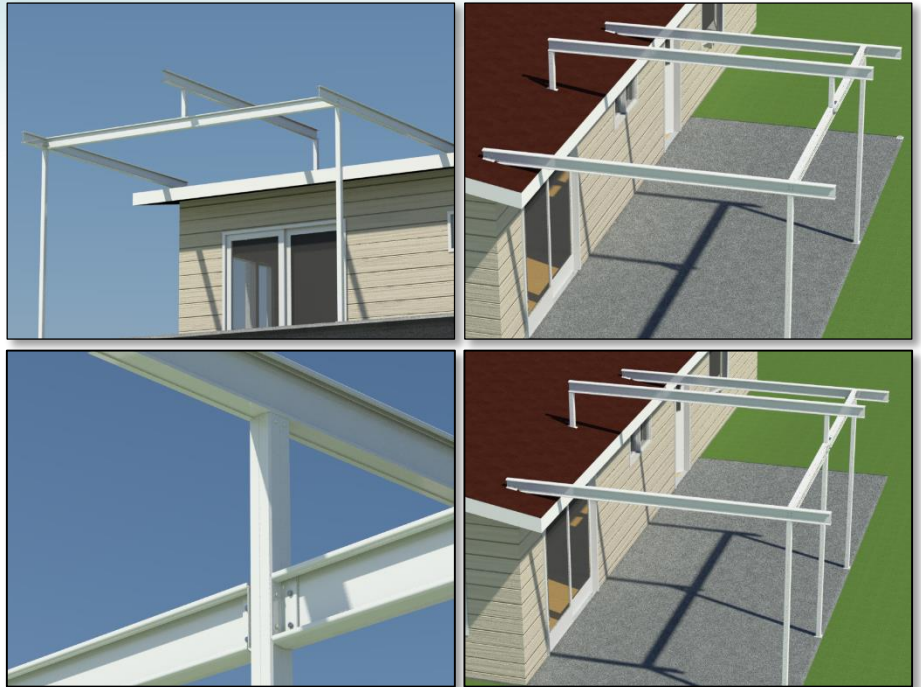

In some cases where the spans on either side of the Ridge Beam is significant or from a simple design preference it may be desirable to install a horizontal cross beam. This beam will be in two pieces as it intersects with the center post. Attachment at the extreme left and right will be into the side Beams with the use of brackets as outlined in 15 Connecting Two Beams With Brackets. At the center the beams will attach to the center post with brackets that are screwed to the left and right of the center post.

## 17 INSTALLING THE T-BARS

### 17.1 INTO HANGING RAIL OR RIDGE BEAM

In most cases all of your T-Bars will be identical, so choose any one and position it at either the left or right edge of the Hanging Rail or forward edge of the gable Ridge Beam. It should be pushed tightly up into the Hanging Rail or Ridge Beam and positioned flush with the outer edge.

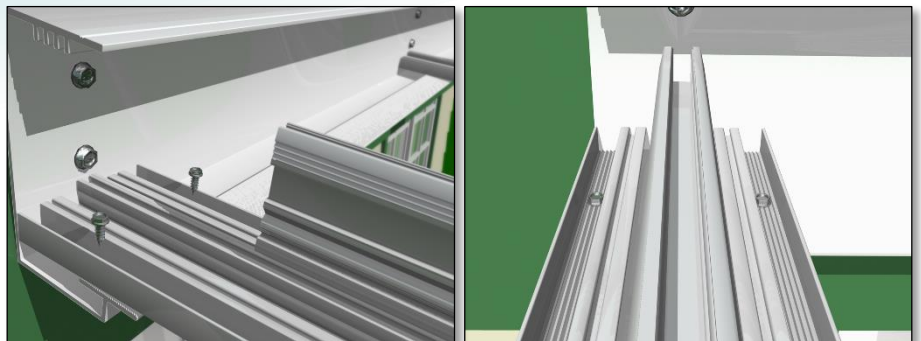



Using #8 x 1/2" Tek screws fasten one on each side of the T-Bar in the serrated area just inside the outer left and right edges of the T-Bar. In the Hanging Rail the screws should be down from the end of the T-Bar approximately 1 3/4" to where the end of the screw will emerge through the inside leg of the Hanging Rail flange on which the T-Bar rests. In the Ridge Beam these screws are positioned within the T-Bar at approximately 1" down from the end of the T-Bar to where the end of the screw will emerge through the inside leg of the Ridge Beam flange on which the T-Bar rests.

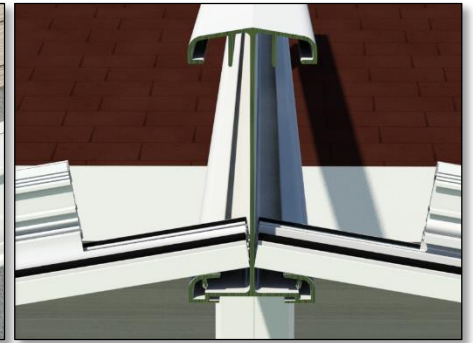

Use two more screws to fasten the same T-Bar to the top of the I-Beam. You should ensure that the Post and I-Beam assembly is running exactly perpendicular using a set square or similar device to determine such. You can then fasten the T-Bar to the I-Beam approximately 1/4" back from the front or outward edge of the Beam. Be sure to recheck that your posts are level at this point before proceeding.

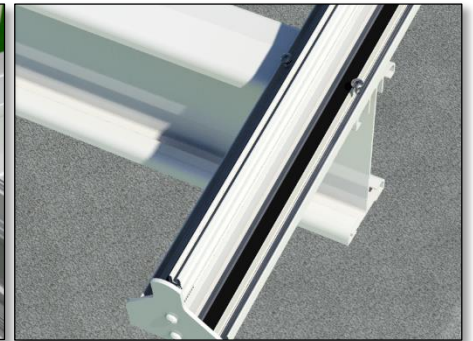
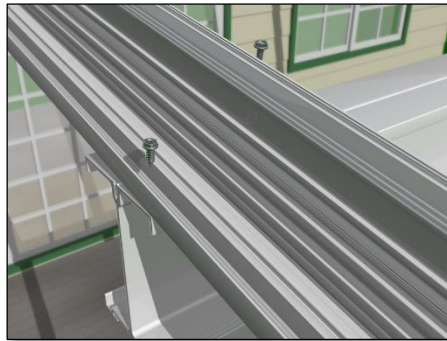

Repeat these steps each subsequent T-Bars as you move across the roof. The distance between the T-Bars or centers will be determined by the width of the acrylic panels being used. The standard full panel width is 47 1/4" giving a T-Bar spacing of 48" and a half panel is 23 1/2" giving a T-Bar spacing of 24 1/4". For varying reasons the roof may be made up of custom width acrylic panels in which the case, the general rule is that the T-Bar spacing should be 3/4" greater than the width of the panels. Your supplier should be able to assist you in determining your centers when you order or take delivery of your roof.

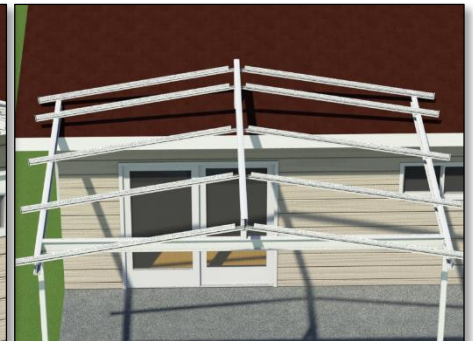
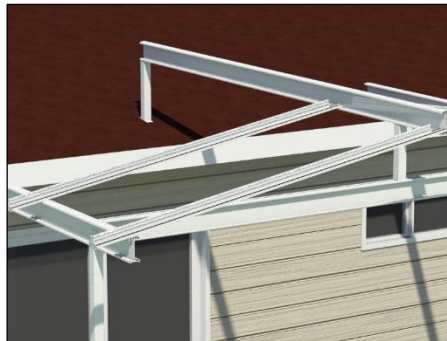

## 18 INSTALLING THE GUTTER

The Gutter Rail is placed at the underside of the lower end of the T-Bars.

Before installing you should determine the placement of any downpipe as you will need to cut a hole through the bottom of the Gutter Rail to position your outlet. Once you have determined the position of such you can then cut this hole with hole saw or similar. The size and shape of this hole will depend on the type of gutter outlet being used, but in most cases a 2" hole will be used for conventional gutter drops.

Foam plugs are provided to seal or "dam" each end of the gutter rail. These simply slide into each end of the gutter to the extent that they are flush with each open end. You may now seal these in place using an appropriate sealant to ensure a water-tight seal for the ends of your gutter.

The inside horizontal leg of the Gutter Rail should be flush with leading or front edge of the T-Bars and in no case should it protrude beyond. A space or gap should be left between the end of the T-Bar and the inner face of the T-Bar cap. This is an allowance for the F-Section which should become evident when installing the acrylic panels.

To fasten it, you use the 1/2" Tek screws provided. Position these fasteners as you did earlier when fastening the T-Bars to the Beam, Hanger and/or Ridge. These should align in the gutter approximately 1/2" up from the end of the T-Bar (not including end cap) to where the end of the screw will emerge through the inside leg of the Gutter flange on which the T-Bar rests.

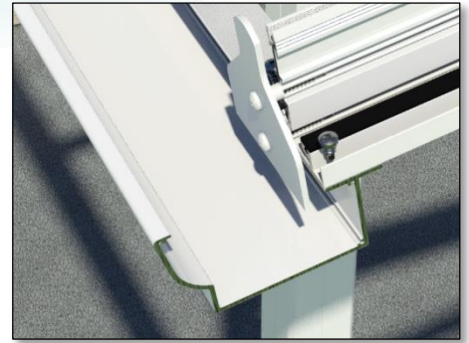

## 19 INSTALLING THE SIDE FASCIA

Prior to installing the caps and roof panels to the outside T-Bars at the left and right or front and back outer edges of your roof, you will need to insert the Side Fascia into each of these T-Bars.

To distinguish the top from the bottom of the Side Fascia you will note that there is an approximate 1" return or 90° leg on the bottom only.

The lower leg of the two inward legs (spaced apart approximately the same distance as the thickness of the acrylic sheet) will rest over the outer gasket race of the outer T-Bars along the entire length of the T-Bar. These inward legs will hit the T-Bar End Caps at the lower end and need to be removed. You will need to cut through both of these legs completely down to the large vertical face of the Fascia at approximately 6"-8" in from the lower end. Then, using a sharp utility knife, score along the corner where the horizontal leg meets the vertical face from the cut to the end of the Fascia. A deep scoring should allow this section to break free after repeatedly working it back and

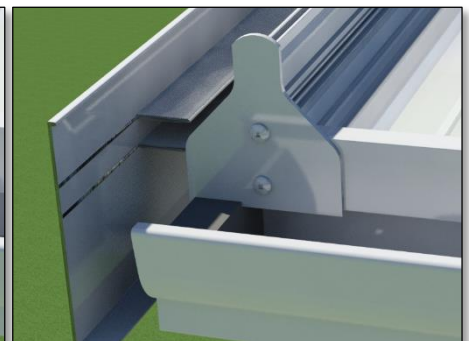
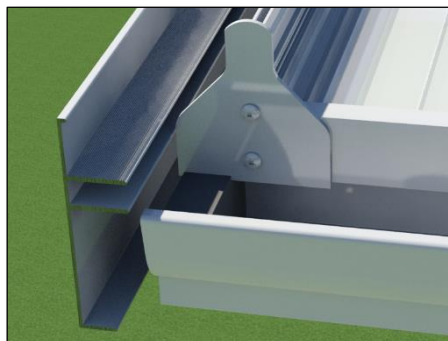
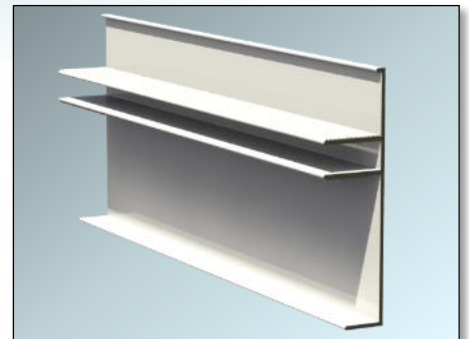

forth. Repeat this for the other inward leg.

At the high side of the fascia or ridge for gables this Side Fascia will need to be mitered equivalent to the pitch of your roof. The Fascia should have been supplied long to facilitate this. Position the Fascia where it ultimately rest and/or take an accurate measurement from the other face of the Gutter following the slope along the side of the T-Bar to the back side of the Hanging Rail or to the center of the ridge. Mark a line across the outer face of the Side Fascia equivalent to the pitch (slope) of the roof to mark where to cut this piece. Using a miter saw or hacksaw cut the end off the Side Fascia along the marked line. The remaining Side Fascia should now be the same length as your complete roof projection or one half of your roof width in the case of gables. It should be square at the bottom with 6"-8" of inward legs removed and mitered at the top to fit cleanly at the Hanger or meet with its mirror at the ridge of a gable.

The bottom of the Side Fascia should fit over the gutter and a Tek screw can be screwed up through the Fascia and Gutter to hold the two together. The lower end of the Side Fascia at the gutter is then finished off with the 1"x1" corners provided. These corners will finish the exposed aluminum end of the side fascia adjacent to the Gutter and fastened with two (2) ½" Tek screws through the corner into the face of the Side Rail. A further screw can be used at the high side of the Side Fascia at the Hanging Rail, through the Side Rail into the adjacent T-Bar.

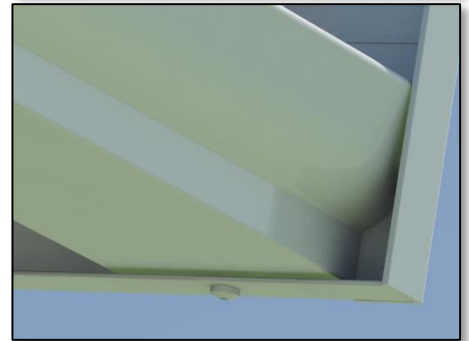
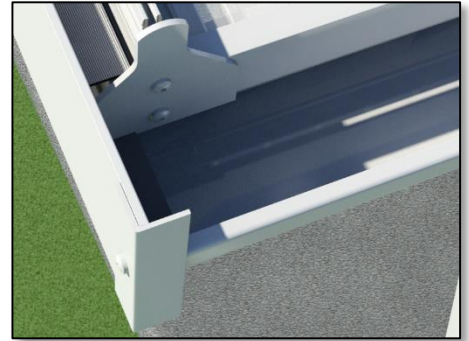

## 20 GASKETING & T-BAR END CAPS

Your T-Bars should come with two lengths of gasket installed down the length of the T-Bar and a T-Bar End Cap installed at one end. Of particular importance here is to ensure that the gasket has not slid up or down beyond the T-Bar and that the gasket is free of any dirt or debris before you proceed to installing the Acrylic panels. This gasket should also come pre-installed into the T-Bar Caps and you should be certain that it is installed flush with both end of the Cap before you proceed to their installation.

Should you need to install or re-install the T-Bar End Caps yourself. When you align the caps with the lower (forward) end of the T-Bars you will notice that the two holes through the caps should line up with the two screw channels in the T-Bars. Simply fasten each end cap with the screws provided.

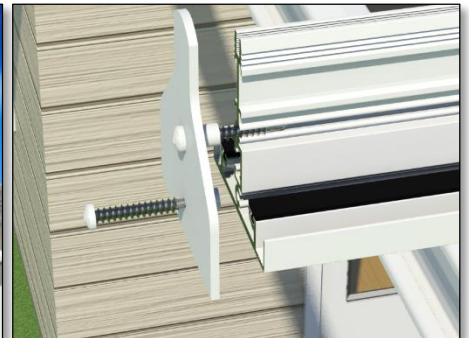
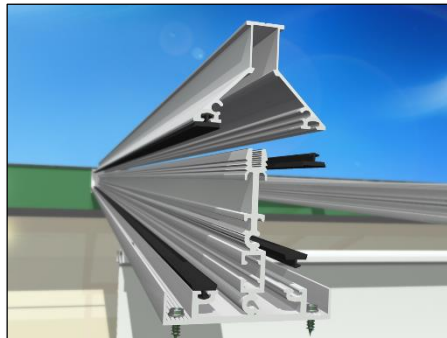



## 21 INSTALLING ROOF PANELS

Take a moment to ensure that your workspace is free of obstacles and that you have the apparatus in place to get up and between the T-Bars at the highest point. Take care from this point forward to avoid marring the roof panels with any abrasive, sharp objects or tools. If your roof panels are of considerable size you may wish to have assistance at this point.

Check the alignment of the F-Section. The F-Section has a leg protruding outward at right angles from the sheet. Conventional roofs will have the F-Section on both ends and gable roofs will have the F-Section at one end and the Terminal Section at the other. When placing the panels, make sure that this leg points upward at the high end of the sheet in the Hanging Rail and downward at the low end of the sheet into the Gutter Rail. The acrylic sheet is manufactured with a NO DRIP® surface on one side which should be indicated along the factory edge of each sheet and should be positioned on your roof system facing outward.

Lift the roof panels into place and center over the gaskets in the T-Bars on each side of it. The bottom should be aligned so that the downward leg of the F-Section is placed tightly against lower portion of the T-Bar. Make sure that the panel is centered with equal space on either side.

As your roof flashing is normally supplied in longer lengths that will span across several panels you should understand the flashing installation (illustrated below) as you work across your roof. You will likely be installing the T-Bar Caps as well as you move across your roof so you should read through the section on installing these caps before you proceed as well.

After you install the first panel you will need to reach up through the second opening to install/adjust the flashing and install the first T-Bar Cap. You will then install the second panel, adjust/install the flashing and then reach over and install the T-Bar Cap over the T-Bar connecting the first two panels. You then move to the next opening and repeat the process as you move across the roof. Working through the openings in the roof allows you to work on the higher areas of the roof without having to physically get on the roof. Although you may very well have to with the last of the panels or for some finishing touches, it is recommended that not work on the roof unless absolutely necessary.

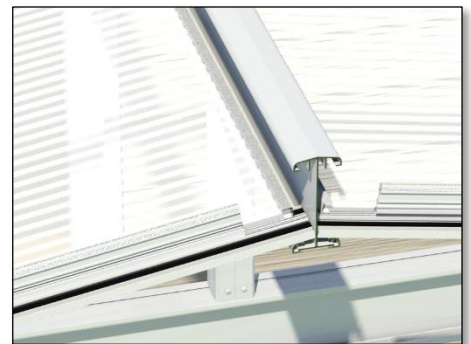
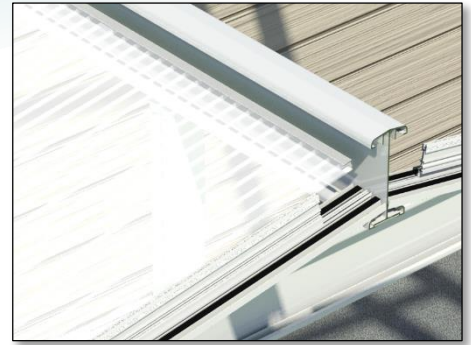

## 22 FLASHING YOUR ROOF

After the first piece of glazing is installed you will need to flash the upper end of the glazing. The flashing should be provided in approximately 8 - 10 foot lengths. These should run across multiple panels and the T-Bars should be notched to accommodate this.

A couple of different sizes are available depending on the type of roof being built. When set on top of the acrylic panels the vertical leg of the flashing will be long enough to reach up into the Hanger or Ridge Beam to very nearly contact the top. In the Hanging rail you will find several downward protruding legs between which the top of the flashing will be inserted. You should always insert the Flashing between two of these legs as far back or as deep into the Hanging Rail

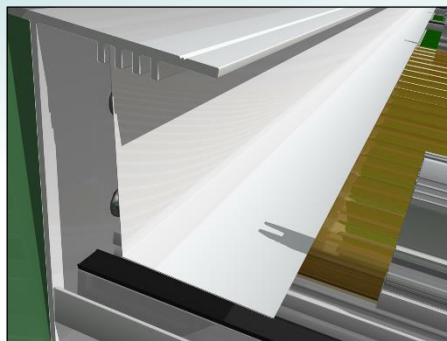



as possible. In the Ridge Beam you will find one downward protruding legs on each side and the upward vertical leg of the flashing should be inserted behind this leg and as close to the center of the beam as possible.

In all cases the lower leg or horizontal section will run down over the top face of the acrylic panel, cover the entire width of each panel and run through adjacent T-Bars. Multiple lengths will likely be required to cover each run of flashing. In this case the individual lengths should overlap each other by at least 6". Fasteners are not required to hold the Flashing in place as this will be achieved through installing the T-Bar Caps.

## 23 INSTALLING THE T-BAR CAPS

Once you have installed the roof panels you may now install the T-Bar Cap over each of the T-Bars. As you will be working over the roof panels; great care should be taken so that you don't damage them or mar the surface.

Make sure that the gasket is completely installed in the gasket race on each side of the cap as described earlier in this guide.

Before installing the T-Bar Cap on the T-Bar located at the left and right outer edge; be sure you review "19 Installing The Side Fascia".

Line up each cap directly over each T-Bar so that the bottom edge of the cap is flush with the bottom edge of the T-Bar. Be sure of your positioning at this point as the following steps are difficult to undo.

Starting at the upper end work your way down the cap and, using a rubber mallet, hammer the cap into place. Be exceptionally careful at this point so that you don't contact the roof panels with the mallet. You may wish to place a block of wood under the mallet at the point of contact as you are hammering. This could give you a greater contact area, protect the finish on the cap and reduce the possibility of slipping and contacting the panels.

Be certain that each cap is all the way down before proceeding to the next. The gasket should spread slightly as it achieves contact with the roof panel creating a watertight seal at this point.

As an option, you can install stainless fasteners to the top of the cap to hold it to the T-Bar more securely. This is optional and may not normally be required. Pre-drill the caps at the exact top center and about every 12" to 16" along the length, prior to installation. The T-Bar is designed to accommodate a #10 - 24 machine screw no longer than 1/2" so you should size your holes accordingly.

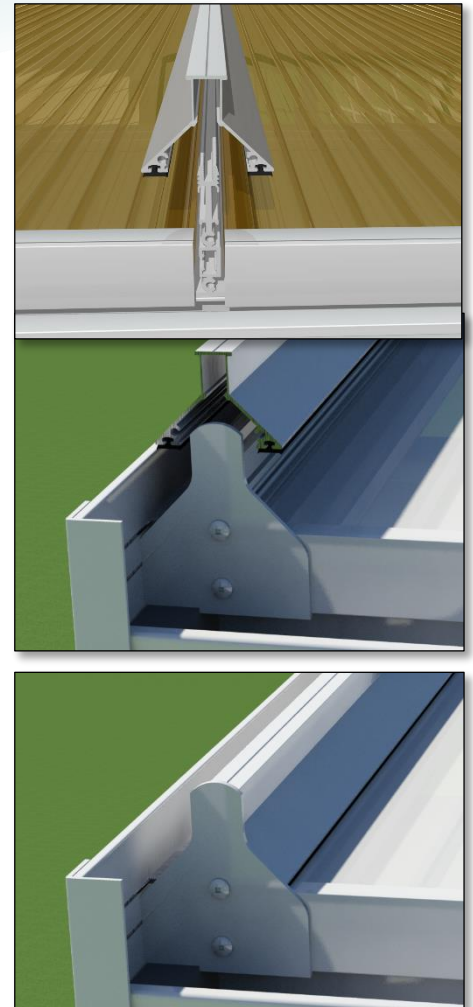

## 24 OPTIONAL COMPONENTS

### 24.1 CORNER GUSSET

Where the underside of an I-Beam meets with a post there is the option to add an ornate fabricated Corner Gusset. Not only is this optional component decorative but it can perform a useful function as well. In cases of free-standing roofs and/or where lateral sway is a concern, this piece can be added to reduce if not eliminate this concern.



### 24.2 RIDGE END SCROLL

At the ridge of a gable roof a decorative scroll is available to cover the end of the Ridge Beam. This is an ideal solution to the impracticality of an end cap where the pitch of the roof can't easily be predetermined.

### 24.3 I-BEAM END SCROLL

The I-Beam that carries the lower end of the T-Bars can be seen below the side fascia. As an alternative to mitering this beam a decorative End Scroll is available to cover it.



## 25 POSTS AGAINST THE HOUSE

In some cases Posts may be required against the structure for varied reasons. This happens occasionally for mobile homes or where architectural control prohibits attaching to the roof. When this is the case the base is attached in the same manner as described above. A Post Top Shoe should be fastened to the structure wall in line with the intended position of the vertical post. You should be certain that this shoe is fastened into a wall stud, header or top wall plate.

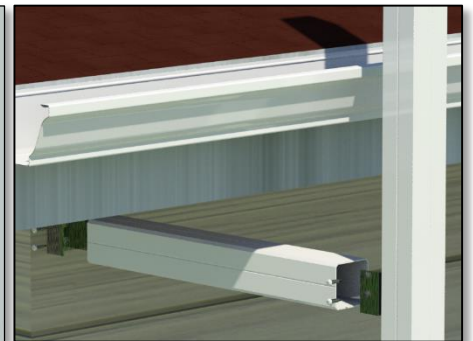
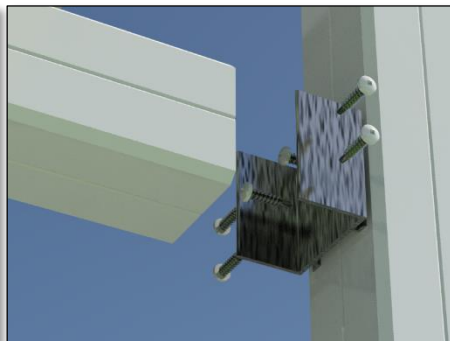

A second Post Top shoe should be attached to the actual post exactly in line with the shoe attached to the structure. A Post should now be cut at a length greater than the distance from the wall to the outer face of the fascia and/or gutter. This represents the distance that the vertical post will be positioned away from the structure. This distance can vary for many reasons and you should temporarily position

your vertical post at its desired location and then make the measurement between this post and the structure wall.

After the post has been cut to length it can be inserted over the Post Shoe at the structure wall. Two self-drilling fasteners can now be used on each side in line with the Post Shoe flanges. The vertical post with the Shoe attached can now be slid over the open end of the spacer post and fastened in the same manner as the other end.

## 26 SPLICES

When the Roof exceeds a standard stock lengths of certain profiles it may be necessary to splice them.

### 26.1 SPLICING BEAMS

Splices are available in sizes appropriate to the type of beam being used. The splice should be fastened using two 1/4" thru bolts at 1 1/2" from the end and spaced 3" apart. In each 12" splice this will space as 1 1/2" / 3" / 3" / 3" / 1 1/2". This will be a total of eight bolts per splice.

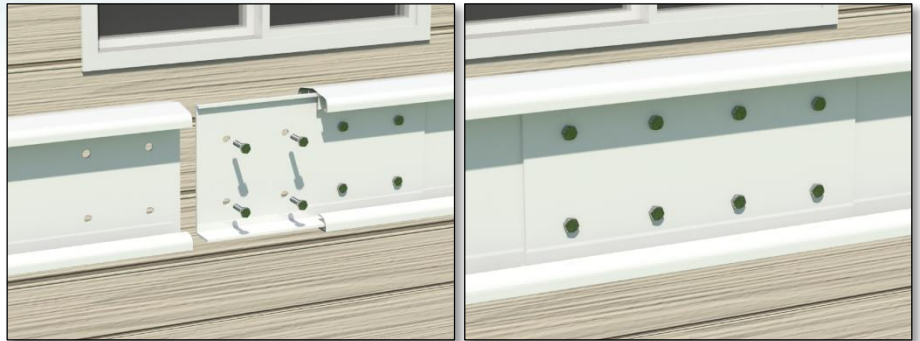

### 26.2 SPLICING THE HANGING RAIL

A Splice is available for the Hanging Rail that will cleanly splice two lengths together and help prevent any water infiltration at this point. When affixed to the wall or fascia of the structure no additional fasteners should be required to hold this splice in place.

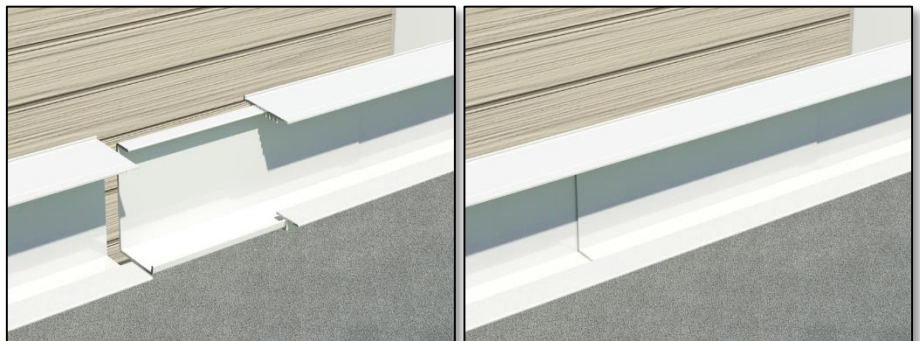

### 26.3 SPLICING THE GUTTER

A Splice is also available for longer lengths of Gutter. It is simply inserted approximately 6 inches into the ends of each connected piece. As the gutter is fastened to the ends of the T-Bars as each is encountered, no fasteners are necessary to hold this splice in place.

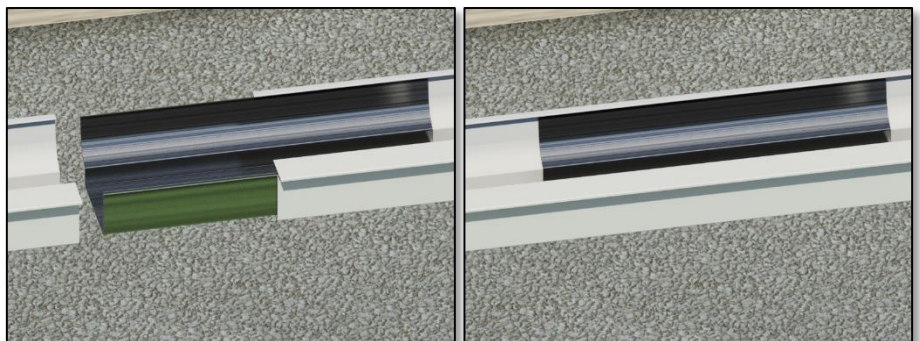

## 27 COMPLETE

At this point your roof should be complete. Take care to remove all your tools and equipment from the roof.

Should you be uncertain of any of the points outlined throughout this guide, return to that section and review the information. If you still require assistance contact your supplier and/or refer to section on Assistance.



## 28 CARE & MAINTENANCE

By following the preceding guidelines, you should have installed a virtually maintenance free roof system. The materials used are of the finest quality and will last for years. However, you should keep the following in mind to maintain the roof at its peak for years to come.

### 28.1 ACRYLIC SHEET

- Use only water, mild detergent and soft rags to clean any surface of the acrylic.
- The acrylic can scratch and care should be taken during any cleaning.
- Never use cleaning fluids, solvents, ammonia or abrasive products to clean any surface of the acrylic.
- It is not recommended that you walk on the sheet.
- Never attempt to fasten the Acrylic Sheet by drilling through the sheet and point fastening. Expansion and contraction can cause the sheet to crack at this point.

### 28.2 GASKETING AND SEALANTS

- Never allow chemicals or solvents to contact the gasketing.
- Use only recommended sealants in conjunction with any of the system components.
- Use only enough sealant to achieve the desired result. Large accumulations of sealant can 'dam' water or redirect it with undesired results.

### 28.3 ALUMINUM COMPONENTS

- Never use solvents to clean the painted surfaces of the aluminum components.
- If you will be painting or 'touching up' the painted surfaces of the aluminum components, do so prior to installation.
- Avoid any hard impacting on the components to avoid denting.
- Avoid scratching the surface of the aluminum components with screwdrivers, utility knives or any such sharp objects.
- Don't attempt to install bent or damaged aluminum components.

### 28.4 THE ROOF SYSTEM

- Use only the components outline in this guide.
- Do not attempt to alter, adapt or improvise the described installation techniques without first checking with your supplier about the feasibility of your intentions.
- If cleaning the outside of the roof with a hose, the water should be directed down the slope and NEVER up the slope.



## 29 ASSISTANCE

Care has been taken to deal with most applications and situations dealing with and arising from the installation and use of the T-Bar Roof System. However, as there are about as many ways to adapt and install the roofs as there are unique installation sites, we are sure to have missed a detail or two. Should you need more information or clarification on any of the details of this guide, answers to any questions, additional products or information on how to locate a particular additional product, contact your supplier. In most cases your supplier will have the experience and knowledge of the products and installation techniques to answer all of your inquiries. Should you require even more information, contact Acrylic Patio Cover Direct at 1-360-658-7281, 1-800-556-0079 or [info@AmericanPatioCovers.com](mailto:info@AmericanPatioCovers.com).

